

# 勁佳光電股份有限公司

## VBEST ELECTRONICS LTD.

### Product Specification For LCD Module

(KVPF-7B-002-16)

Model NO. : VTG322402-7TWFWA(L.F)

REVISION : 1

APPROVAL FOR SPECIFICATIONS ONLY

APPROVAL FOR SPECIFICATIONS AND SAMPLE

CUSTOMER :	APPROVED BY :
S.T.D	

### VBEST LCM R&D CENTER

APPROVED BY	CHECKED BY	PREPARED BY	
DIRECTOR	MANAGER	Mechanism Engineer	Electronic Engineer

勁佳光電股份有限公司總公司  
**VBEST ELECTRONICS LTD.**  
 台北縣中和市建一路 186 號 12 樓  
 12F,NO.186, JIAN 1st RD., CHUNG HO CITY,  
 TAIPEI HSIEN, TAIWAN, R.O.C  
 TEL : +886 2 8227-2788  
 FAX : +886 2 8227-2789

勁佳光電股份有限公司台中分公司  
**VBEST ELECTRONICS(T.C) LTD**  
 台中縣潭子鄉台中加工出口區建國路 19 號  
 NO.19,CHIEN KUO ROAD.T.E.P.Z TANTZE  
 427 TAICHUNG HSIEN TAIWAN R.O.C  
 TEL : +886 4 2532-8889  
 FAX : +886 4 2532-6689

東莞莞城德寶電子廠  
**VBEST ELECTRONICS(B.V.I)LTD.**  
 廣東省東莞市城區東縱大道天寶路 9 號  
 NO.9,Tian Bao Rd.,Dong Zong St.,Dong Guan City  
 Guang Dong, China.  
 TEL : +86 769 220 5258  
 FAX : +86 769 220 7258

勁佳光電(昆山)有限公司  
**VBEST ELECTRONICS(KUNSHAN) CO.,LTD.**  
 江蘇省昆山市玉山鎮高科技工業園城北路 8 號  
 NO.8,Chengbei Rd., Hi-Tech Industry Park ,  
 Yushan Town , Kunshan City , Jiangsu,China.  
 TEL : +86 512 5778 7288  
 FAX : +86 512 5777 0688

<http://www.vbest.com.tw>

**VBEST****MODEL NO.****PAGE**

VTG322402-7TWFWA

SPEC &amp; SAMPLE

2

**TABLE OF CONTENTS**

<b>NO</b>	<b>CONTENTS</b>	<b>PAGE</b>
1	COVER	1
2	CONTENTS	2
3	RECORD OF REVISION	3
4	MODULE NUMBERING SYSTEM	4
5	GENERAL SPECIFICATION	5
6	LCM DRAWING	6
7	ABSOLUTE MAXIMUM RATING	7
8	ELECTRO-OPTICAL CHARACTERISTICS	7
9	OPTICAL CHARACTERISTICS	8
10	INTERFACE PIN ASSIGNMENT	10
11	BLOCK DIAGRAM	11
12	RECOMMEND POWER SUPPLY CIRCUIT	12
13	BACKLIGHT	13
14	RELIABILITY	14
15	LIFE TIME	14
16	SPECIFICATION OF QUALITY ASSURANCE	15
17	HANDLING PRECAUTION	23
18	PACKING METHOD	25





MODULE NUMBERING SYSTEM

**V B C 1216 01 - 1 R T N N A**

Serial No:A~Z

Backlight Color:  
**N:**Without Backlight;  
**A:**Amber;**B:**Blue;**G:**Green;  
**L:**Yellow;**O:**Orange;**R:**Red;  
**Y:**Yellow Green;**W:**White

Backlight Type:  
**N:**Without Backlight;  
**E:**EL; **F:**CCFL; **L:**LED; **P:**LAMP

LCD Model:  
**T:**TN; **H:**HTN; **G:**STN Gray; **E:**ECB  
**Y:**STN Yellow;**B:**STN Blue; **W:**FSTN  
Black/White;  
**N:**Others;**O:**OLED ;**P:**PLED;**C:**CSTN;  
**F:**TFT;**P:**PLED;**L:**LTPS

LCD Type:  
**R:** Reflective/Positive;  
**S:** Reflective/Negative  
**F:** Transflective/Positive  
**G:**Transflective/Negative  
**U:**Transmissive/Positive  
**T:**Transmissive/Negative ; **N:**Others

Temperature Range & View Direction:  
General Purpose: **1:**6H **2:**12H **3:**3H **4:**9H  
**5:** Others  
High Performance: **6:**6H **7:**12H **8:**3H **9:**9H  
**0:** Others

STD Product Serial No. : 01~99  
Customer Made Serial No. :A1,A2...A9,B1,B2...B9,C1..

Display Function:  
Segment Number/Characters Lines/ Column and Row Dots  
Length \* Width of Other

Display Type:  
**C:**Character Type; **G:**Graphic Type; **S:**Segment Type

Package Type:  
**B:**COB; **F:**COF; **G:**COG; **H:**Heat Seal; **S:**SMT; **T:**TAB; **O:**Others

**GENERAL SPECIFICATION**

<b>ITEM</b>	<b>CONTENTS</b>
Module Size	168 MAX(W) * 111.0(H) * 7.4(D)mm
Display Format	320(W) * 240(H) DOTS
View Area	120.0(W) * 90.0(H)mm
Dot Size	0.33(W) * 0.33(H) mm
Dot Pitch	0.36(W) * 0.36(H)mm
LCD Type	FSTN / Transmissive/ Negative
View Angle	12 O'clock
Duty Ratio	1/240 Duty
Bias	1/13Bias
DC to DC circuit	Excluded
Controller	Excluded
Approx. weight	186g



**ABSOLUTE MAXIMUM RATING(Ta=25 VSS=0V)**

Item	Symbol	Min.	Type	Max.	Unit	Humidity
Supply Voltage for Logic	$V_{DD}-V_{SS}$	-0.3	--	+7	Volt	--
Power Supply for LCD	$V_{DD}-V_{EE}$	0	--	+30	Volt	--
Input Voltage	$V_{IN}$	-0.3	--	VDD	Volt	--
Operating Temperature	Top	-20	--	+70		Note1
Storage Temperature	Tst	-30	--	+80		Note2

Note1: Background color changes slightly depending on ambient temperature. This phenomenon is reversible.

Ta 70 : 75%RH max

Ta>70 : absolute humidity must be lower than the humidity of 75%RH at 70

Note2: Ta at -30 will be <48hrs, at 80 will be <120hrs

**ELECTRO-OPTICAL CHARACTERISTICS (Ta=25 )**

Item	Symbol	Condition	Min.	Typ.	Max.	Unit
Power Supply for Logic	$V_{DD}-V_{SS}$	--	--	5.0	--	Volt
Input Voltage	$V_{IL}$	L level	0	--	0.3 $V_{DD}$	Volt
	$V_{IH}$	H level	0.7 $V_{DD}$	--	$V_{DD}$	
LCD Module Driving Voltage	$V_{DD}-V_o$	Ta=25	22.1	22.8	23.5	Volt
Power Supply Current for LCM	$I_{DD}$	$V_{DD}=5.0V$ $V_{EE}=-24.0V$ $V_{DD}-V_o =22.8V$	--	15.5	21.7	mA
						mA

**OPTICAL CHARACTERISTICS**

Item	Symbol	Min.	Typ.	Max.	Unit	Condition	Note
Viewing Angle Cr 2	=0°	1	--	10	--	deg. T=25°C	1.2
	=180°	2	--	40	--		
	=90°	3	--	30	--		
	=270°	4	--	30	--		
Contrast Ratio	Cr	--	7	--	--	T=25°C	3
Response Time (rise)	Tr	--	200	300	ms	T=25°C	4
Response Time (fall)	Tf	--	200	300	ms	T=25°C	4



**Note 1. Definition of angle 1& 2**

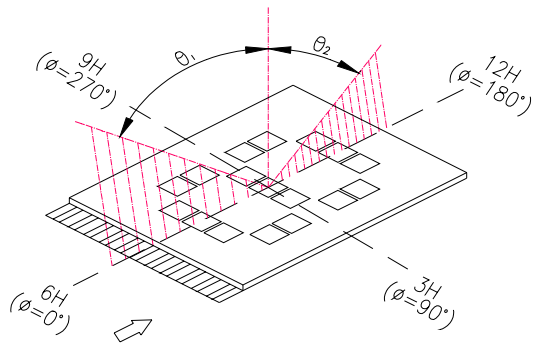

**Note 2. Definition of angle 3& 4**

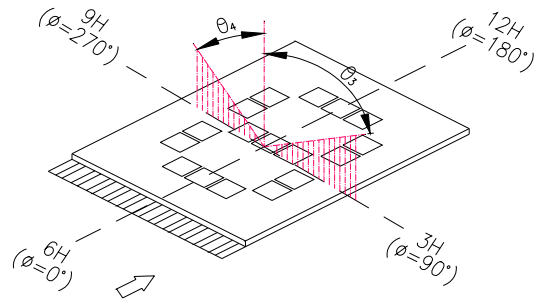

**Note 3. Definition of contrast ratio (Cr)**

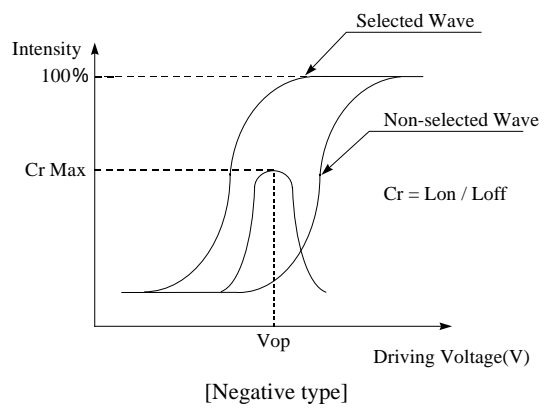
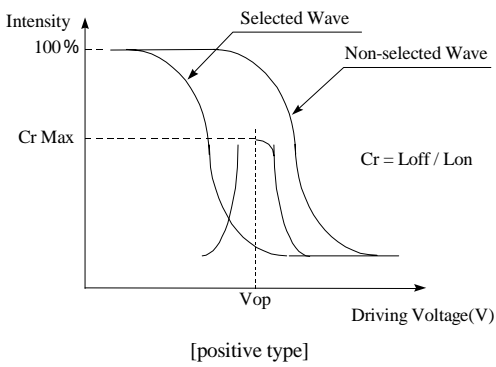

**Note 4. Definition of response time**

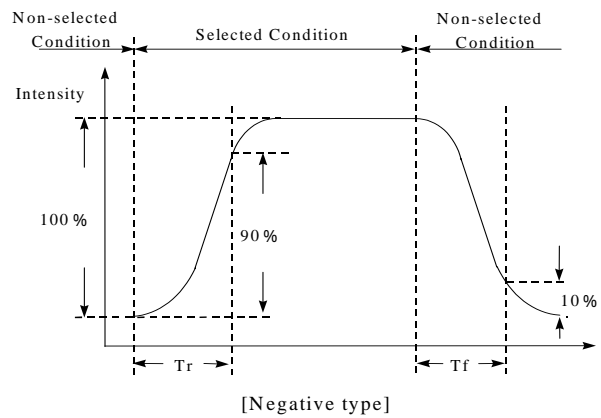
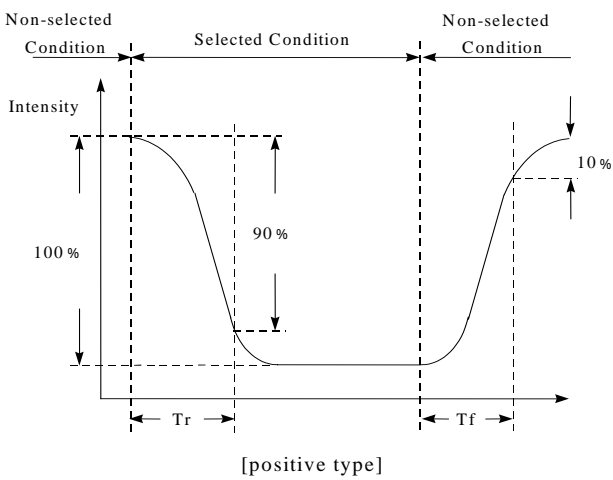

**INTERFACE PIN ASSIGNMENT**

PIN	SYMBOL	FUNCTIONS
1	D0	Display data signal
2	D1	
3	D2	
4	D3	
5	/DISPOFF	H:Display ON , L: Display OFF
6	FRAME	Scan start up signal
7	NC	No connection
7	LOAD	Input data latch signal
9	CP	Data input clock signal
10	VDD	Power supply for logic(+5V)
11	VSS	Signal ground (0V)
12	VEE	Power supply for LCD
13	VO	LCD contrast adjust voltage
14	FGND	Front panel ground

**CCFL CONNECTOR:**

PIN NO	SYMBOL	FUNCTIONS
1	HOT	POWER SUPPLY FOR CCFL(HOT)
2	NC	NO CONNECTION
3	NC	NO CONNECTION
4	GND	POWER SUPPLY FOR CCFL (GND)



**BLOCK DIAGRAM**

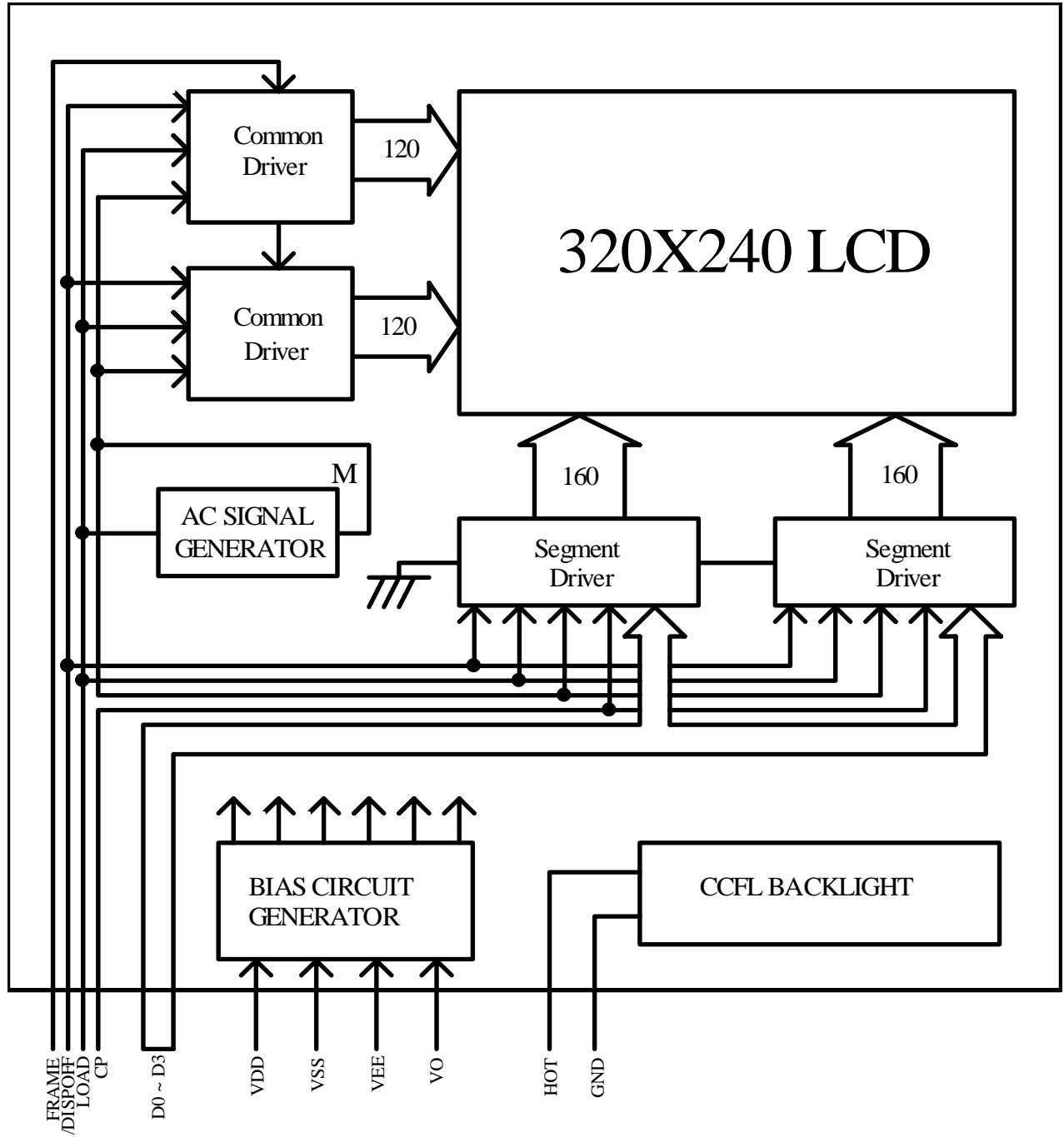



### RECOMMEND POWER SUPPLY CIRCUIT

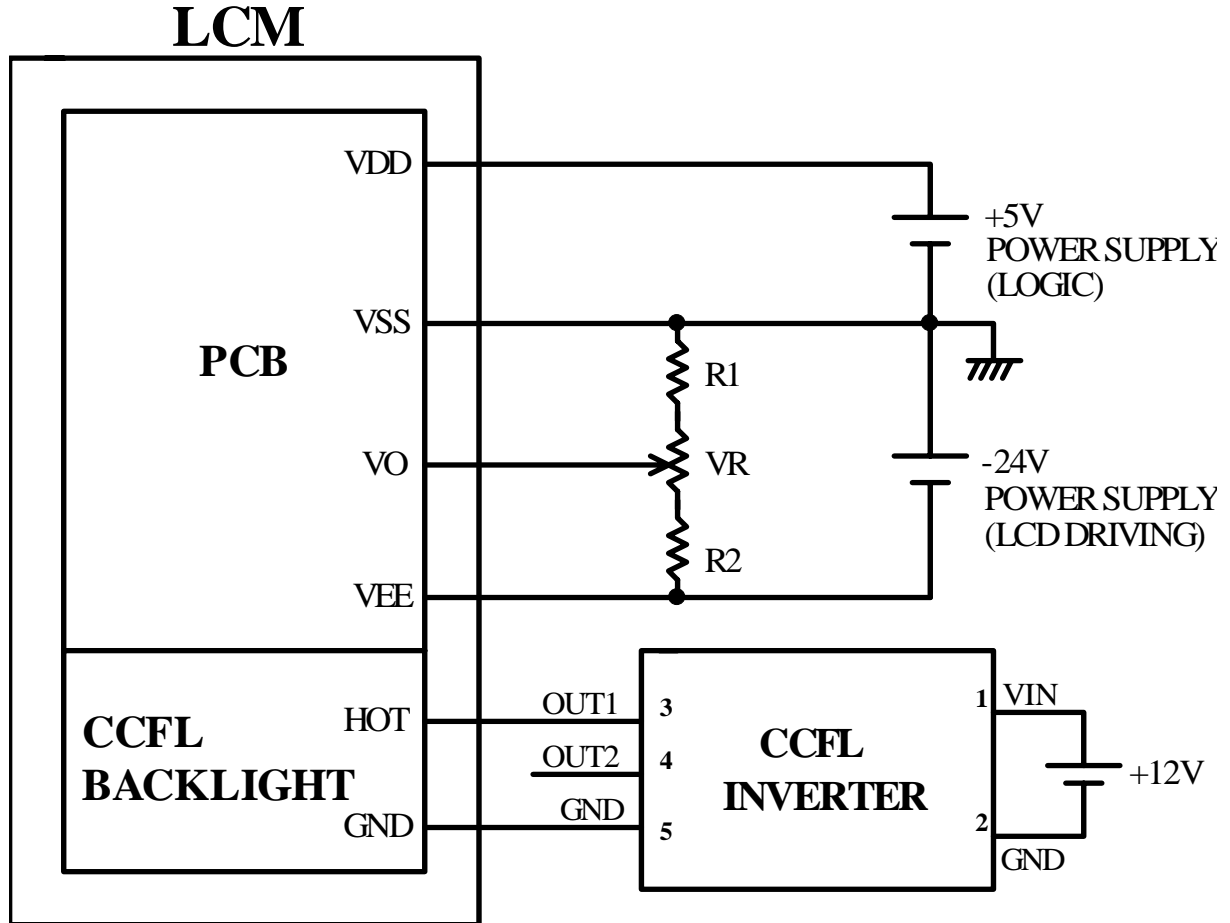

- (1)  $R1+VR+R2=10K\sim 20K$  Ohm
- (2) Recommend CCFL INVERTER:  
CXA-L10L-L (TDK)

**Backlight:**

## Electrical Characteristics :

Item	Condition	Min.	Typ.	Max.	Unit
CCFL Driving voltage	Ta=25	500	-	-	Vrms
CCFL Frequency	-	-	35	-	KHZ
CCFL Current	Ta=25	-	-	7.0	mA
CCFL Starting discharge voltage	Ta=25	*(1000)	-	-	V

\*() for reference

## Optical characteristics :

CFL : INITIAL, Ta=25 , IL=5mA, DISPLAY DATA SHOULD BE ALL "ON".

Item	Condition	Min.	Typ.	Max.	Unit	Note
Brightness	Surface of LCM display	-	12	-	cd/m <sup>2</sup>	1,
Rise time	At brightness 80%	-	5	-	min	-
Brightness tolerance of display	Surface of LCM display	-	-	±30	%	1,2

## Notes :

1. It is 10 minutes, after CCFL is started, to measure the deviation of brightness.

Operating voltage for LC driving : 23.2V ( $V_{DD}-V_O$ )

brightness control : 100%

2. [( Max. brightness or Min. brightness – Average brightness ) / Average brightness] × 100

**RELIABILITY****Environmental Test**

NO.	Test Item	Test Condition	Test Time	Note
1	Low temperature storage	-30±2	240H	-
2	High temperature storage	80±2	240H	-
3	Low temperature operation	-20±2	240H	-
4	High temperature operation	70±2	240H	-
5	High temperature/ Humidity storage	60±2 90%±5%RH	240H	Without dewing
6	Thermal shock storage	-30 (30min) 25 (5min) +80 (30min)	10 cycles	-

**Mechanical Test**

NO.	Test Item	Test Condition	Note
1	Vibration test	Sweep for 1 min at 10Hz , 55Hz , 10Hz , amplitude 1.5mm 15 minutes each in the X , Y and Z directions (Total 45 minutes)	Non operation state
2	Drop test	One angle,three edges and six sides. 75cm above the ground(no weight difference)	Non operation state

**LIFE TIME**

Item	Description
1.	Functions, Performance, appearance, etc. shall be free from remarkable deterioration within 50,000 hours under ordinary operating and storage conditions room temperature (25±10°C) , normal humidity(45±20%RH),and in area not exposed to direct sun light.

**SPECIFICATION OF QUALITY ASSURANCE****1.1 Purpose**

This standard for quality assurance should affirm the quality of LCD module products to supply to ( Purchaser ) by VBEST ELECTRONIC LTD.  
( Supplier )

**1.2 Standard for Quality Test**

1.2.1 Test method: According to MIL-STD-105E, General Inspection Level II take a single time.

1.2.2 Electronic Assemblies Standard is according to IPC-AA610 REV. C . CLASS 2

1.2.3 The defects classify of AQL as following list.

Classify	Inspect item	Nonconforming status	AQL	Remark
Critical defect	1.Display damage	( 1 ) Non-Display	AQL=0.65	Product no function
		( 2 ) Occur high current		
		( 3 ) Segment missing		
		( 4 ) LCD with wrong viewing direction		
		( 5 ) Back light unlighted		
	2.Dimension not correct	( 1 ) PCB and bezel out of specification	AQL=0.65	Can not assembly
Major defect	1.Display	( 1 ) Display scanned Disorder	AQL=1.0	--
		( 2 ) display defect		
	2.Back-light	( 1 ) Flash , duct		
		( 2 ) Wong color		
Minor defect	1.LCD	( 1 ) Dust ( Black spot , white spot )	AQL=2.50	Appearance defect
		( 2 ) Polarizer scratch		
		( 3 ) Reflective polarizer with bubble		
		( 4 ) Display segment transfigure		
		( 5 ) Color out of the range of sample color		
Total			AQL=2.50	

**1.3 NONCONFORMING ANALYSIS & DEAL WITH MANNERS****1.3.1 Nonconforming analysis :**

- Purchaser should supply the detail data of non-conforming sample and the improper state. After accepting the detail data from purchaser , the analysis of Nonconforming should be finished in two weeks. If supplier cannot finish analysis on time , must announce purchaser.

**1.3.2 Disposition of nonconforming :**

If the customer will find any defected product during assembly time , supplier will replace the good product for every defect after. Both supplier and customer should analysis the reason and discuss the disposition of nonconforming when the reason of nonconforming is not sure.

**1.4 Agreement items**

Both sides should discuss together when the following problems happen.

**1.4.1** There is any problem of standard of quality assurance , and both sides

Think that must be modified.

**1.4.2** There is any argument item which does not recorded in the standard of quality assurance.**1.4.3** Any other special problem.



## 1.5 Standard of the product appearance test

### 1.5.1 Manner of appearance test

- The test must be under 20W×2 or 40W fluorescent light , and the distance of view must be at 30cm.
- When test the model of transmissive product must add the reflective plate.
- The test direction is base on about 45° of vertical line.

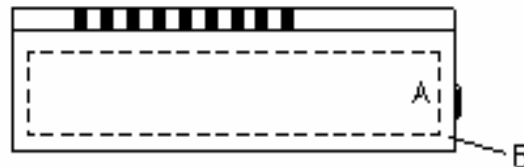
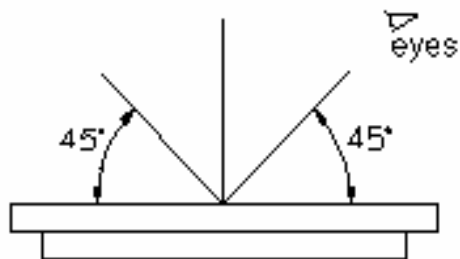



- Definition of area :

A、 area : viewing area

B、 area: : out of viewing area(outside viewing area)

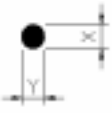

1.5.2 Standard of appearance inspection : ( Unit: mm )

Name:LCM	Inspection Specification																																			
Scope	LCM																																			
Item	Criterion																																			
1.Electronic	<p>(1)Display scanned must be complete.</p> <p>(2)Can not non-display</p> <p>(3)The consumer current can not over the specification</p> <p>(4)Test result as the following must be reject:</p> <p>1.Display incomplete</p> <p>2.Occur high current</p> <p>3.Display defect</p>																																			
2.Black spot , white spot , dust in LCD	<p>(1)Round type : As following drawing</p> $\Psi = (X+Y) / 2$ <div style="display: flex; align-items: center; justify-content: center;">  <table border="1" style="border-collapse: collapse; text-align: center;"> <thead> <tr> <th>Size</th> <th colspan="2">Acceptable Q'TY</th> </tr> <tr> <th>Area</th> <th>A</th> <th>B</th> </tr> </thead> <tbody> <tr> <td><math>\Psi &lt; 0.1</math></td> <td>Accept no dense</td> <td rowspan="4">Accept No Dense</td> </tr> <tr> <td><math>0.1 &lt; \Psi &lt; 0.2</math></td> <td>2</td> </tr> <tr> <td><math>0.2 &lt; \Psi &lt; 0.25</math></td> <td>1</td> </tr> <tr> <td><math>0.25 &lt; \Psi</math></td> <td>0</td> </tr> </tbody> </table> </div> <p>(2)Line type : (As following drawing)</p> <div style="display: flex; align-items: center; justify-content: center;">  <table border="1" style="border-collapse: collapse; text-align: center;"> <thead> <tr> <th>Length</th> <th>Width</th> <th colspan="2">Acceptable</th> </tr> <tr> <th colspan="2">Area</th> <th>A</th> <th>B</th> </tr> </thead> <tbody> <tr> <td>Accept</td> <td><math>0.02 \geq L</math></td> <td>Accept no dense</td> <td rowspan="4">Accept No Dense</td> </tr> <tr> <td><math>3.0 \geq L</math></td> <td><math>0.03 \geq L</math></td> <td rowspan="2">2</td> </tr> <tr> <td><math>2.5 \geq L</math></td> <td><math>0.05 \geq L</math></td> </tr> <tr> <td>---</td> <td><math>0.05 \geq L</math></td> <td>As round type</td> </tr> </tbody> </table> </div> <p style="text-align: center;">Total acceptable Q'TY (1) + (2) <math>\leq 3</math></p>	Size	Acceptable Q'TY		Area	A	B	$\Psi < 0.1$	Accept no dense	Accept No Dense	$0.1 < \Psi < 0.2$	2	$0.2 < \Psi < 0.25$	1	$0.25 < \Psi$	0	Length	Width	Acceptable		Area		A	B	Accept	$0.02 \geq L$	Accept no dense	Accept No Dense	$3.0 \geq L$	$0.03 \geq L$	2	$2.5 \geq L$	$0.05 \geq L$	---	$0.05 \geq L$	As round type
Size	Acceptable Q'TY																																			
Area	A	B																																		
$\Psi < 0.1$	Accept no dense	Accept No Dense																																		
$0.1 < \Psi < 0.2$	2																																			
$0.2 < \Psi < 0.25$	1																																			
$0.25 < \Psi$	0																																			
Length	Width	Acceptable																																		
Area		A	B																																	
Accept	$0.02 \geq L$	Accept no dense	Accept No Dense																																	
$3.0 \geq L$	$0.03 \geq L$	2																																		
$2.5 \geq L$	$0.05 \geq L$																																			
---	$0.05 \geq L$	As round type																																		

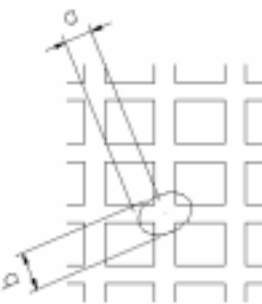

Name:LCM	Inspection Specification												
Scope	LCM												
Item	Criterion												
3.Segmenter transfigure(Digit, word , sign)	<p>c.Alignment layer defect :</p> $\Psi = (a+b) / 2$  <table border="1" data-bbox="582 963 1316 1288"> <thead> <tr> <th>Size <math>\Psi</math></th> <th>Acceptable QTY</th> </tr> </thead> <tbody> <tr> <td><math>\Psi \leq 0.4</math></td> <td>Accept no dense</td> </tr> <tr> <td><math>0.4 &lt; \Psi \leq 1.0</math></td> <td>5</td> </tr> <tr> <td><math>1.0 &lt; \Psi \leq 1.5</math></td> <td>3</td> </tr> <tr> <td><math>1.5 &lt; \Psi \leq 2.0</math></td> <td>2</td> </tr> <tr> <td>Total acceptable QTY</td> <td>7</td> </tr> </tbody> </table>	Size $\Psi$	Acceptable QTY	$\Psi \leq 0.4$	Accept no dense	$0.4 < \Psi \leq 1.0$	5	$1.0 < \Psi \leq 1.5$	3	$1.5 < \Psi \leq 2.0$	2	Total acceptable QTY	7
Size $\Psi$	Acceptable QTY												
$\Psi \leq 0.4$	Accept no dense												
$0.4 < \Psi \leq 1.0$	5												
$1.0 < \Psi \leq 1.5$	3												
$1.5 < \Psi \leq 2.0$	2												
Total acceptable QTY	7												
4.Color	Sample of the lowest acceptable quality level.												
5.Back-light	<p>(1)The color of backlight should correspond its specification.</p> <p>(2)Not allow flash and unlighten on backlight.</p> <p>(3)Not allow larger than 0.25mm dust on backlight.</p>												
6.COB	<p>(1)Not allow the PAD of wire bond exposed.</p> <p>(2)Not allow the line type of wire bond on resin.</p> <p>(3)Not allow bubble and dust on resin.</p>												

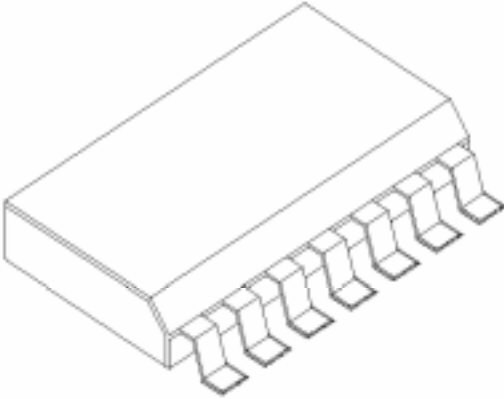

Name:LCM	Inspection Specification
Scope	LCM
Item	Criterion
7.PCB	(1)Not allow dirty and reminded solder on PCB.  (2)Not allow scratch on pin PAD.

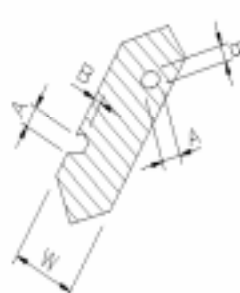

Name:LCM	Inspection Specification																		
Scope	LCM																		
Item	Criterion																		
1.Polarizer scratch	Following the dust specification of time type.																		
2.Polarizer ripple	Not allow get in side Viewing Area .																		
3.Polarizer bubble	<p>(1)Bubble could be seen by eyes exigently to be judged According to black spot specification.</p> <p>(2)Not allow polarize jutting glass outside.</p> <table border="1" style="margin-left: auto; margin-right: auto;"> <thead> <tr> <th>Size</th> <th colspan="2">Acceptable QTY</th> </tr> <tr> <th>Area</th> <th>A</th> <th>B</th> </tr> </thead> <tbody> <tr> <td><math>\Psi &lt; 0.2</math></td> <td>Accept no dense</td> <td rowspan="4">Accept No Dense</td> </tr> <tr> <td><math>0.2 &lt; \Psi &lt; 0.5</math></td> <td>3</td> </tr> <tr> <td><math>0.5 &lt; \Psi &lt; 1.0</math></td> <td>2</td> </tr> <tr> <td><math>1.0 &lt; \Psi</math></td> <td>0</td> </tr> <tr> <td colspan="2">Total acceptable QTY</td> <td>3</td> </tr> </tbody> </table>	Size	Acceptable QTY		Area	A	B	$\Psi < 0.2$	Accept no dense	Accept No Dense	$0.2 < \Psi < 0.5$	3	$0.5 < \Psi < 1.0$	2	$1.0 < \Psi$	0	Total acceptable QTY		3
Size	Acceptable QTY																		
Area	A	B																	
$\Psi < 0.2$	Accept no dense	Accept No Dense																	
$0.2 < \Psi < 0.5$	3																		
$0.5 < \Psi < 1.0$	2																		
$1.0 < \Psi$	0																		
Total acceptable QTY		3																	
4.Segmenter transfigure(Digit, word , sign)	<p>(1)PIN hole , transfigure : (See below)</p> <p>a. Segment display:</p>  <table border="1" style="margin-left: auto; margin-right: auto;"> <thead> <tr> <th>Width</th> <th>Acceptable</th> </tr> </thead> <tbody> <tr> <td><math>W \leq 0.4</math></td> <td><math>\Psi \leq 0.2</math> and <math>\Psi \leq 1/2w</math></td> </tr> <tr> <td><math>W \geq 0.4</math></td> <td><math>\Psi \leq 0.25</math> and <math>\Psi \leq 1/3v</math></td> </tr> </tbody> </table> <p>Note:  W : Segment width  <math>\Psi</math> : <math>(AB)/2</math>  Only allow one defect in one segment.  <math>\Psi</math> under 0.10mm is acceptable.</p>	Width	Acceptable	$W \leq 0.4$	$\Psi \leq 0.2$ and $\Psi \leq 1/2w$	$W \geq 0.4$	$\Psi \leq 0.25$ and $\Psi \leq 1/3v$												
Width	Acceptable																		
$W \leq 0.4$	$\Psi \leq 0.2$ and $\Psi \leq 1/2w$																		
$W \geq 0.4$	$\Psi \leq 0.25$ and $\Psi \leq 1/3v$																		

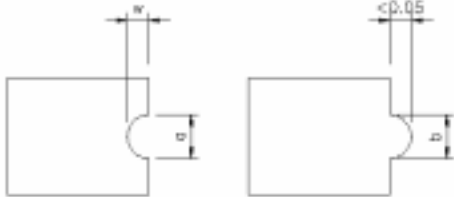
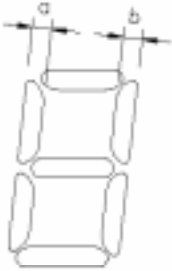
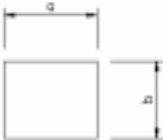

Name:LCM	Inspection Specification														
Scope	LCM														
Item	Criterion														
<p>5.Segmenter transfigure(Digit, word , sign)</p>	<p>b.dot Matrix display:</p>  <table border="1" data-bbox="582 813 1321 1144"> <thead> <tr> <th>Size</th> <th>Acceptable QTY</th> </tr> </thead> <tbody> <tr> <td><math>a, b \leq 0.1</math></td> <td>Accept no dense</td> </tr> <tr> <td><math>(a + b) / 2 \leq 0.1</math></td> <td>Accept no dense</td> </tr> <tr> <td><math>0.5 &lt; \Psi &lt; 1.0</math></td> <td>3</td> </tr> <tr> <td>Total acceptable QTY</td> <td>7</td> </tr> </tbody> </table> <p>(2)a.Segment are not same width</p>  <table border="1" data-bbox="989 1319 1410 1525"> <tbody> <tr> <td><math>a \geq b</math></td> <td><math>a / b \leq 4 / 3</math></td> </tr> <tr> <td><math>a &lt; b</math></td> <td><math>a / b &gt; 4 / 3</math></td> </tr> </tbody> </table> <p>b.Segment are not equal no length and size within <math>\pm 15\%</math> of production specification.</p> 	Size	Acceptable QTY	$a, b \leq 0.1$	Accept no dense	$(a + b) / 2 \leq 0.1$	Accept no dense	$0.5 < \Psi < 1.0$	3	Total acceptable QTY	7	$a \geq b$	$a / b \leq 4 / 3$	$a < b$	$a / b > 4 / 3$
Size	Acceptable QTY														
$a, b \leq 0.1$	Accept no dense														
$(a + b) / 2 \leq 0.1$	Accept no dense														
$0.5 < \Psi < 1.0$	3														
Total acceptable QTY	7														
$a \geq b$	$a / b \leq 4 / 3$														
$a < b$	$a / b > 4 / 3$														



## HANDLING PRECAUTION

### 1、 Mounting Method

The panel of the LCD Module consists of two thin glass plates with polarizes which easily get damaged since the Module is fixed by utilizing fitting holes in the printed circuit board. Extreme care should be taken when handling the LCD Modules.

### 2、 Caution of LCD handling & cleaning

When cleaning the display surface, use soft cloth with solvent (recommended below) and

Wipe lightly.

-Isopropyl alcohol

-Ethyl alcohol

-Trichlorotrifluoroethane

Do not wipe the display surface with dry or hard materials that will damage the polarize surface.

Do not use the following solvent :

-Water

-Aromatics

### 3、 Caution against static charge

The LCD Module use C-MOSLSI drivers, so we recommend end that you connect any unused input terminal to VDD or VSS, do not input any signals before power is turned on.

And ground your body, Work/assembly table. And assembly equipment to protect against static electricity.

### 4、 Packaging

-Modules use LCD elements, and must be treated as such. Avoid in tense shock and falls from a height.

-To prevent modules from degradation. Do not operate or store them exposed directly to sunshine or high temperature/humidity.

### 5、 Caution for operation

-It is indispensable to drive LCD's with in the specified voltage limit since the higher voltage than the limit shorten LCD life.

An electrochemical reaction due to direct current causes LCD deterioration, Avoid the use of -Response time will be extremely delayed at lower temperature than the operating temperature range and on the other hand at higher temperature LCD's show dark color in them.

However those phenomena do not mean malfunction or out of order with LCD's. Which will come back in the specified operating temperature range.

- If the display area is pushed hard during operation, some font will be abnormally displayed but it resumes normal condition after turning off once.

- A slight dew depositing on terminals is a cause for electro-chemical reaction resulting in terminal open circuit.

Usage under the relative condition of 40 , 50%RH or less is required.



## 6、 Storage

In the case of storing for a long period of time (for instance. For years) for the purpose or replacement use,

The following ways are recommended.

- Storage in a polyethylene bag with sealed so as not to enter fresh air outside in it, And with no desiccant.
- Placing in a dark place where neither exposure to direct sunlight nor light is. Keeping temperature in
  - the specified storage temperature range.
  - Storing with no touch on polarizer surface by the anything else. (It is recommended to store them as they have been contained in the inner container at the time of delivery)

## 7、 Safety

It is recommendable to crash damaged or unnecessary LCD into pieces and wash off liquid crystal by using solvents such as acetone and ethanol. Which should be burned up later.

When any liquid crystal leaked out of a damaged glass cell comes in contact with your hands, please wash it off well with soap and water.

## 8.TERMS OF WARRANT

### 1.Acceptance inspection period

The period is within one month after the arrival of contracted commodity at the buyer's factory site.

### 2.Applicable warrant period

The period is within twelve months since the date of shipping out under normal using and storage conditions.



### PACKING METHOD

Packing Method

CUSTOMER : STD

MODEL : VTG322402-7TWFWA

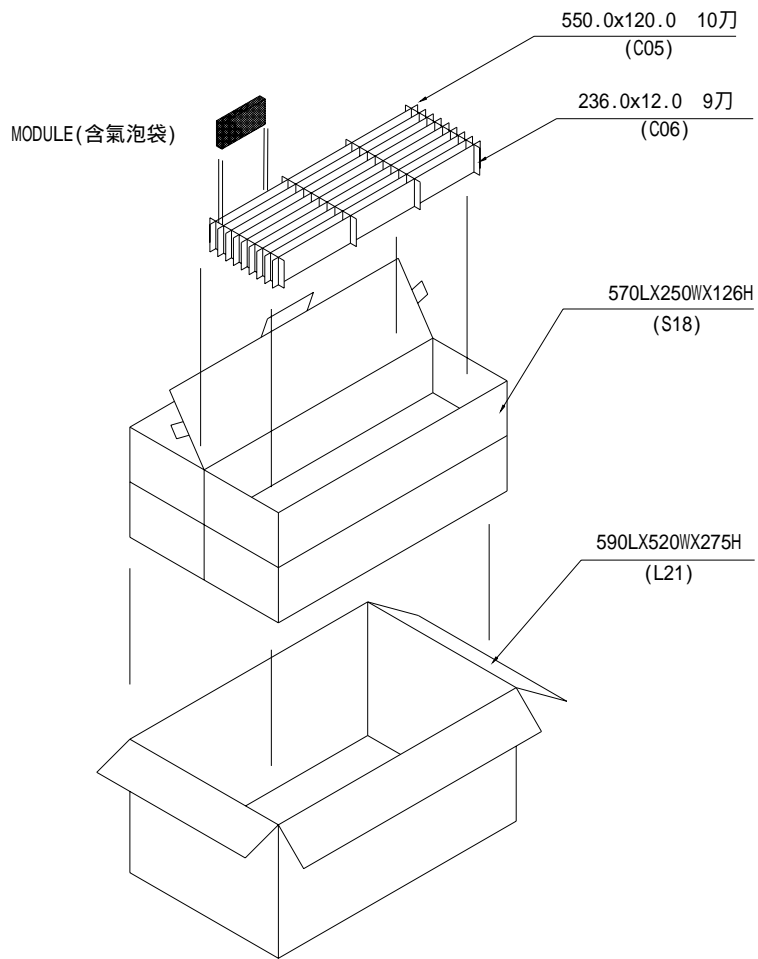

#### PARTS LIST

	ITEM	SIZE(LxWxH) unit:mm	MATERIAL	Q.T.Y	NOTE
1	CARD BOARD(C05)	550.0x120.0 10刀	CARTON	36	
2	CARD BOARD(C06)	236.0x120.0 9刀	CARTON	16	
3	INTERNAL BOX(S16)	570.0x250.0x126.0	CARTON	4	
4	EXTERNAL BOX(L21)	590.0x520.0x275.0	CARTON	1	
5	PRODUCT	168.0x111.0x7.4		96	